



OVL-II™ Series Bi-Level Electronic Eye

Barrier-Free Cooler



Standard finish is Stainless Steel

Optional Finishes (extra cost)

- Aztec Gold
- Galaxy Gray Marblyte™ (Bowl Only)
- Black Onyx Marblyte™ (Bowl Only)

Optional Accessories (extra cost)

- Vandal-Resistant Kit
- Water Filter
- Easy-Flex™ Bubbler
- Cane Apron

Each OVL-II™ SEREE-Q consists of 3 cartons as follows:

- Mounting Frame
- Cooling Unit-SJ8-Q
- Fountain, Panels & Misc. Parts

JOB NAME: _____

 ENGINEER/CONTRACTOR NAME:

 APPROVAL: _____
 DATE: _____

MODEL OVL-II™ SEREE-Q



This water cooler is certified to NSF/ANSI 61.

GENERAL

Modular, electric refrigerated, bi-level wall-mounted water cooler designed to be easily accessible to physically challenged and able-bodied individuals. When properly installed, unit meets state and federal requirements as defined by the Americans with Disabilities Act. Unit is certified to NSF/ANSI 61 and meets requirements of the Safe Drinking Water Act. Unit provides 50° F water at 80° F inlet water and 90° F ambient.

FOUNTAIN

Oval shape fountain, non-corrosive stainless steel, with brushed satin finish. Contour-formed basin with rounded corners and edges. Oval fountain shape requires less neck extension and bending for the wheel chair user.

BUBBLER

Exclusive one-piece, chrome-plated two-stream mound-building bubbler with non-removable anti-squirt feature and integral hood insures a satisfying drink of water.

AUTOMATIC STREAM HEIGHT REGULATOR

Self-closing assembly is located inside unit to prevent tampering. Unit resists corrosion and liming. A constant stream height is automatically maintained under line pressures that vary from 20 to 105 psi.

AUTOMATIC ACTUATION

Model OVL-II™SEREE-Q features infra-red light beam emitting sensor and a solenoid valve on the extended right receptor. Upon interruption of the light beam, the sensor actuates the solenoid valve to flow water. User does not have to touch the water cooler to obtain a drink of water. Supplied with a built-in time delay to avoid nuisance actuation from passers-by. On the left side, the self-closing, semi-circular push bar can be actuated at any point on its 180° radius.

INLET STRAINER

Easily cleaned in-line strainer screen traps particles of 140 microns or larger before they enter the waterway.

REFRIGERATION SYSTEM

Hermetically sealed, positive start compressor with lifetime lubrication and built-in overload protection, efficient capillary sizing, large capacity dryer-strainer, and self-lubricated fan cools copper/aluminum condenser. System uses R134A refrigerant. Protected by Halsey Taylor's Limited 5 Year Warranty.

MOUNTING FRAME

Mounting frame is manufactured of corrosion resistant, galvanized steel. Open construction designed for ease of installation. Mounting frame can be shipped in advance for rough-in installation.

PANELS

Constructed of stainless steel, number 300 series with satin finish. Removable lower panel provides access to plumbing and refrigeration system. Panels overlap wall opening 1/2".

SUGGESTED SPECIFICATIONS

Shall deliver 7.5 GPH of 50° F water at 90° F ambient and 80° F inlet water. Fountain shall include infra-red sensor, contour-formed basin to eliminate splashing and standing water, and rounded corners and edges. Bubbler shall be chrome plated, two-stream, mound- building type. Cooling unit shall have a high efficiency positive start compressor using R134A, with pressurized counterflow cooling evaporator/chiller. Cooler shall comply with ANSI 117:1 and ADA for visual and motion disabilities. The manufacturer shall certify the unit to meet the requirements of NSF/ANSI 61, and the Safe Drinking Water Act. Unit complies with ARI Standard 1010.

NOTE: Continued product improvement makes specifications subject to change without notice. See Halsey Taylor website for most current spec sheet.

NOTE: Water will only flow from bubbler when unit has electrical connection.

OVL-II™ BARRIER-FREE SERIES

Model No.	GPH Capacity Cooled to 50° F*				Base Rate Cap.	F.L. Amps	Shipping Weight lb.	Rated Watt Usage
	Ambient Air Temp							
	70°F	80°F	90°F†	100°F				
OVL-II™ SEREE-Q	9.3	8.3	7.5	6.8	7.5	4.0	140	370

* With projector service and tap water at 80° F

† UL listed and complies with ARI Standard 1010

Trap and service stop not included



OVL-II™ SEREE-Q

OVL-II™ Electronic Eye Barrier-Free Bi-Level Cooler

(CONTINUED)

WALL OPENING

IMPORTANT: It is necessary to create a wall opening 37 1/2" W x 37 3/4" H and 4 1/2" above the floor line.

MOUNTING INSTRUCTIONS

Refer to rough-in for location of plumbing and electrical sources. The support frame is to be installed first. The shelf for the water chiller should be assembled to the wall frame, and then place chiller into position. Hang upper panel to hanger on frame. Fountains are to be attached to panel and wall frame. Water service lines, waste lines, and electrical are assembled as required. The bottom panel is attached last, after a final check for leaks and correct functions of fountains and chiller. (For details see the installation instructions.)

Installation requires trap to be installed in wall. Trap and service stop not included.

OPERATING PRESSURES:

Supply water - 105 psi maximum

Minimum 40 psi supply line pressure required in special circumstances where both sides of bilevel are in use simultaneously to ensure adequate stream height. Use of water filter in this situation is not recommended.

ELECTRICAL DATA

Junction box for a (3) wire 10 AMP branch circuit. Standard 120 volt, 60 HZ, single phase.

FRONT VIEW

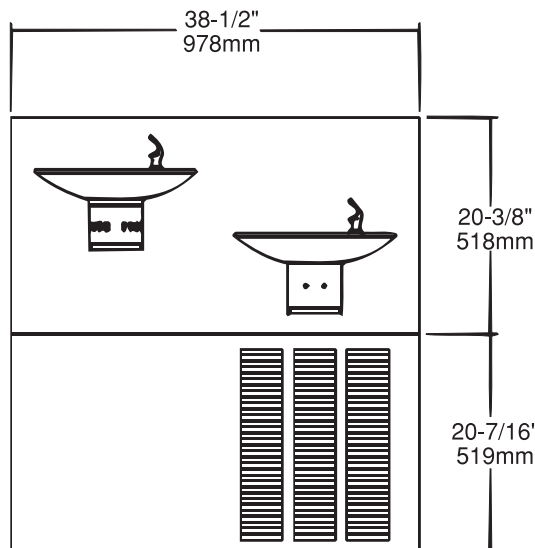

TOP & SIDE VIEWS

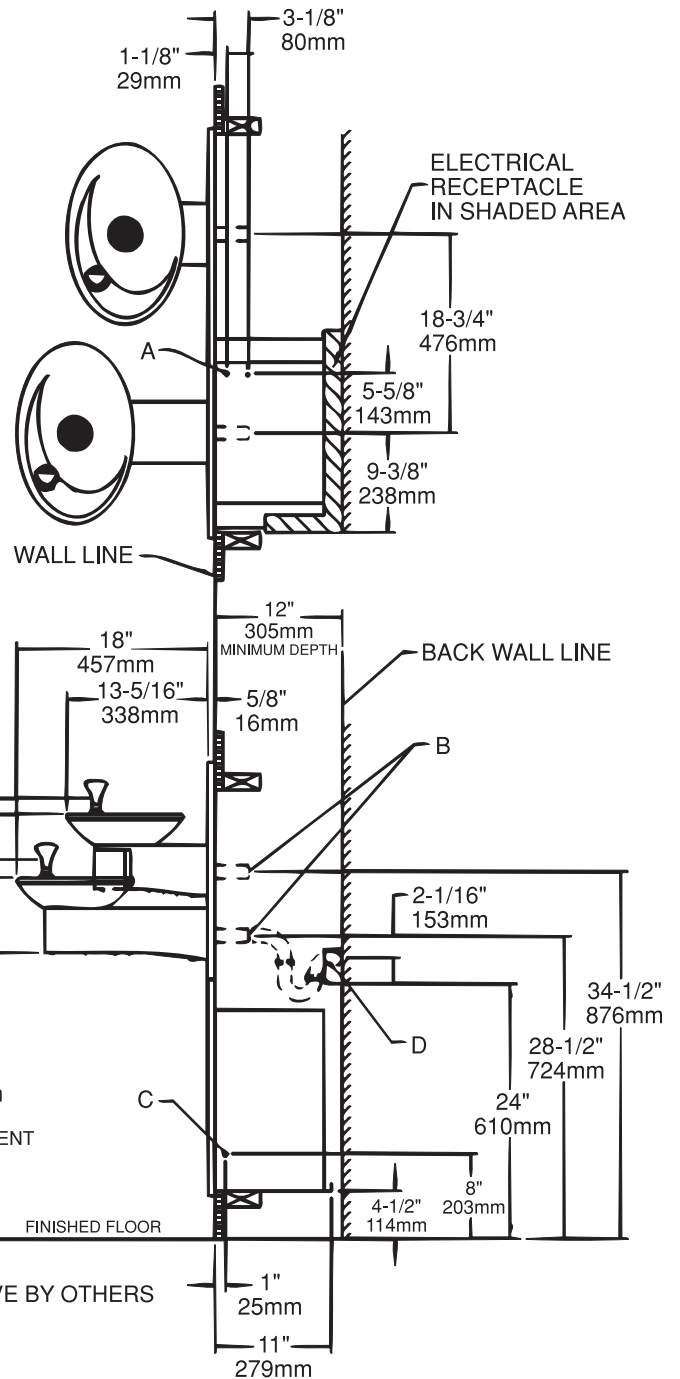

LEGEND:

- A = 3/8" O.D. TUBE CONNECT (CHILLER WATER INLET) SHUT OFF VALVE BY OTHERS
- B = 1-1/4" WASTE TUBE (ELBOW & TRAP NOT PROVIDED)
- C = ELECTRICAL INLET
- D = ELECTRICAL OUTLET LOCATION ADDITIONAL UL/CSA LISTED GROUNDED OUTLET (BY OTHERS) REQUIRED FOR 115 VOLT, 60HZ

Halsey Taylor®